

# MCP

## 系列不锈钢多级离心泵 SERIES STAINLESS MULTI-STAGE CENTRIFUGAL WATER PUMP



### WORKING CONDITIONS

Max Temperature of Fluid up to +110°C  
Max Pressure 10bar,  
Max Ambient Temperature up to 40°C

### 工作条件:

最高流体温度为110°C  
最大可承受的压力10bar  
最高环境温度40°C

MCP series stainless multi-stage centrifugal water pump can be fit for industrial area, as like drink liquid transfer, pressure increasing, water supply and washing. The feature of the product is power-saving, steadily, durable. This pump has big capacity and normal pressure.

MCP 不锈钢多级离心泵主要用于工业领域，亦可适用于管道增压、供水、冲洗等场合。其显著特点是节能、运行稳定、使用寿命长。其水力特性为高扬程中等流量。



H m PERFORMANCE CHART AT n=2900r/min 折算到2900r/min时性能

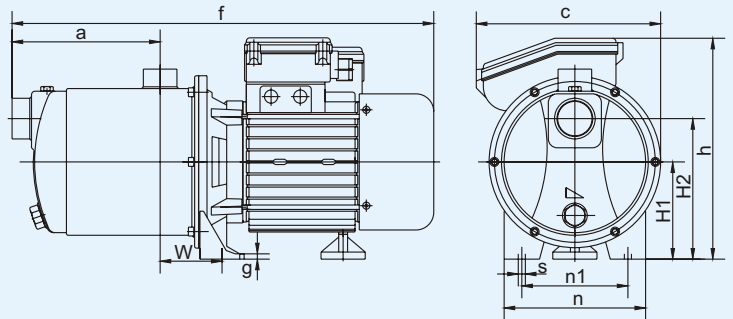
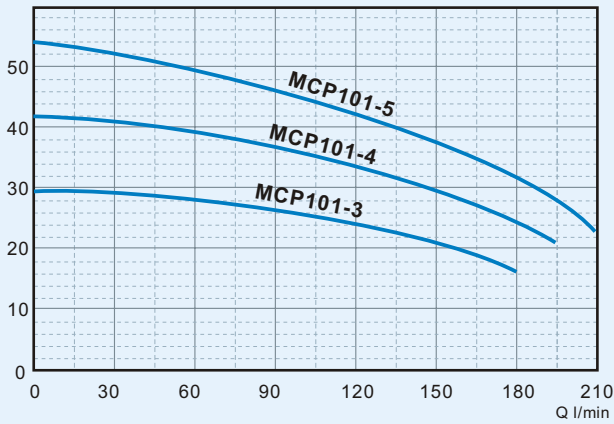

### DIMENSIONS 安装尺寸

TYPE 型号	Dimensions 外形尺寸 mm											Weight 重量 (kg)		Packing Size 包装尺寸 (mm)			Packing QTY. 包装数量
	a	f	h	H2	H1	C	n	n1	w	g	s	NW	GW	L	W	H	20' Cont 20'柜
MCP-3	108	418	250	159	110	210	160	120	70	6	8	14	15	440	210	275	1100
MCP-4	138	448	250	159	110	210	160	120	70	6	8	15.6	16.6	460	210	275	1050
MCP-5	168	478	250	159	110	210	160	120	70	6	8	17	18	500	210	275	960

### TECHNICAL DATA 技术参数

TYPE 型号	Output Power 输入功率		Current 电流 (A)	Capacitor 电容器 (F)	H.max 最高扬程 (m)	Q.max 最大流量 (l/min)	Size 进出口径 (inch)	S.Head 最大吸程 (M)
	KW	HP						
MCP-3	1.1	1.5	6.4	30	30	180	1.25"X1"	8
MCP-4	1.5	2	9.5	40	40	195	1.25"X1"	8
MCP-5	1.8	2.5	11	40	50	210	1.25"X1"	8

标准零件配置：不锈钢叶轮、不锈钢轴。可根据客户的其它参数及材料的要求，制作其它规格的产品。

Standard data and equipment: stainless iron impeller, stainless steel shaft. Others model and material will be available upon request.